



JZ-PRV101

<p>EN</p> <p>Cable laying roller fit for installations of cables up to $\varnothing 90$ mm on straightway or bending positioning of cable-trays.</p> <p>Composed by:</p> <ul style="list-style-type: none"> galvanized steel frame, provided two locking devices, one fixed and one adjustable, n. 4 running roller made of galvanized steel, mounted on shielded ball bearings. 	<p>D</p> <p>Kabelpritschen-Montagerolle, verzinkt, oben geschlossen, geeignet für Kabel bis $\varnothing 90$ mm.</p> <p>Bestehend aus:</p> <ul style="list-style-type: none"> verzinktem Stahlrahmen mit einer fixen und einer verstellbaren Verankerungsklammer, 4 verzinkte Stahlrollen, gelagert mittels doppelt geschützter Kugellager. 	<p>E</p> <p>Rodillo de montaje de plateformas de cables, galvanizado, parte superior cerrada, apto para cables de hasta 90 mm \varnothing.</p> <p>Compuesto por:</p> <ul style="list-style-type: none"> bastidor de acero galvanizado con una pinza de anclaje fija y otra ajustable, 4 rodillos de acero cincado, montado sobre cojinetes de esferas apantallados. 	<p>F</p> <p>Galet de montage, galvanisé et fermé en haut, pour la pose de câbles de 90 mm de \varnothing max sur des chemins de câbles.</p> <p>Composé:</p> <ul style="list-style-type: none"> d'un cadre en acier galvanisé avec un crochet d'ancrage fixe et un crochet d'ancrage réglable, de 4 galets en acier galvanisé montés sur roulements à billes blindés. 	<p>I</p> <p>Rullo posacavi adatto per la posa in rettilineo o curva su passerelle, di cavi fino al $\varnothing 90$ mm max.</p> <p>Composto da:</p> <ul style="list-style-type: none"> telaio in acciaio zincato con due dispositivi di fissaggio uno fisso e uno regolabile, n. 4 rulli di scorrimento in acciaio zincato montati su cuscinetti a sfere schermati.
--	---	---	--	---

Accessories • Zubehör • Accesorios • Accessoires • Accessori

<p>[1], [2] Spare roller comes complete of screwed shaft M10, ball-bearings, nuts and bolts.</p>	<p>[1], [2] Ersatzrolle aus verzinktem Stahl, mit Gewindestift M10, Kugellager, Beilagscheiben und Mutter.</p>	<p>[1], [2] Rodillo de repuesto con perno roscado M10, cojinetes, arandelas y bulones.</p>	<p>[1], [2] Galet de rechange muni d'axe fileté M10, roulements, rondelles et boulons.</p>	<p>[1], [2] Rullo di ricambio, completo di perno filettato M10 cuscinetti, rondelle e bulloni.</p>
---	---	---	---	---

[1]	[2]			
FE	FE			
art.				
JZ-PRV101ERW	JZ-PRV101ERS			
285x135x590	6,3 kg	100 daN	$\varnothing 90$ mm	$\varnothing 40$ x 170/200 mm

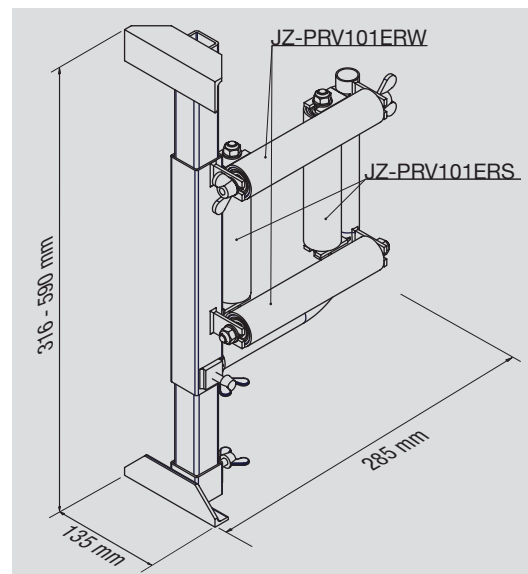

Subject to technical changes without prior notice. Technische Änderungen vorbehalten. Soggetto a variazioni tecniche senza preavviso.