

**EN**

Cable laying ground roller fit for corner installations of cables with **ø 280 mm** max., with swinging vertical rollers. Composed by:

- galvanized steel frame
- n. 2 pair of running rollers and n. 1 horizontal made of **galvanized steel** mounted on self lubricating brass bushes

**D**

Kabel-Eckrolle, geeignet zum Verlegen von Kabeln bis max. **ø 280 mm** in Kurven, mit schwingenden vertikalen Rollen. Bestehend aus:

- verzinktem Stahlgestell
- zwei vertikalen Rollenpaare und einer horizontalen Rolle aus **verzinktem Stahl**, gelagert mittels selbstschmierende Messingbuchsen

**E**

Rodillo de tendido de cables para el tendido en curva de cables con **ø 280 mm** máx., con rodillos verticales oscilantes. Compuesto por:

- bastidor de acero cincado
- n. 2 pares de rodillos verticales y n. 1 horizontal, en **acero cincado** montado sobre cojinetes de bronce auto-lubricantes

**F**

Rouleaux câbler adapté pour la pose incurvée de câbles mesurant jusqu'à **ø 280 mm** max., avec rou-leaux verticaux oscillants. Composé de:

- châssis en acier zingué
- n. 2 paires de rouleaux verticaux et n. 1 horizontal, en **acier galvanisé** monté sur bronze bagues auto-lubrifiantes

**I**

Rullo posacavi adatto per la posa in curva di cavi fino al **ø 280 mm** max., con rulli verticali oscillanti. Composto da:

- telaio in acciaio zincato
- n. 2 coppie di rulli di scorrimento verticali e n. 1 orizzontale, in **acciaio zincato** montati su boccole in bronzo autolubrificanti

**Accessories • Zubehör • Accesorios • Accessoires • Accessori**

Spare roller comes complete of screwed shaft M14, ball-bearings, nuts and bolts. Horizontal [1] and vertical [2] version.

Ersatzrolle aus verzink-tem Stahl, mit Gewindestift M14, Kugellager, Beilagscheiben und Mutter. Horizontale [1] und vertikale [2] Version.

Rodillo de repuesto con perno roscado M14, cojinetes, arandelas y bulones. Versión horizontal [1] y vertical [2].

Galet de rechange muni d'axe fileté M14, roulements, rondelles et boulons. Version horizontale [1] et verticale [2].

Rullo di ricambio, completo di perno filettato M14 cuscinetti, rondelle e bulloni. Versione orizzontale [1] e verticale [2].

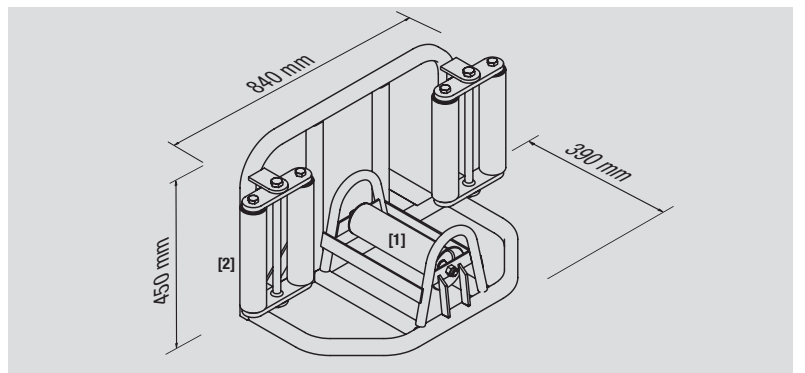

840 x 390 x 450 mm	33,5 kg	600 daN	300 daN	ø 280 mm	ø 80 - 110 x 270 mm	ø 60 x 270 mm