

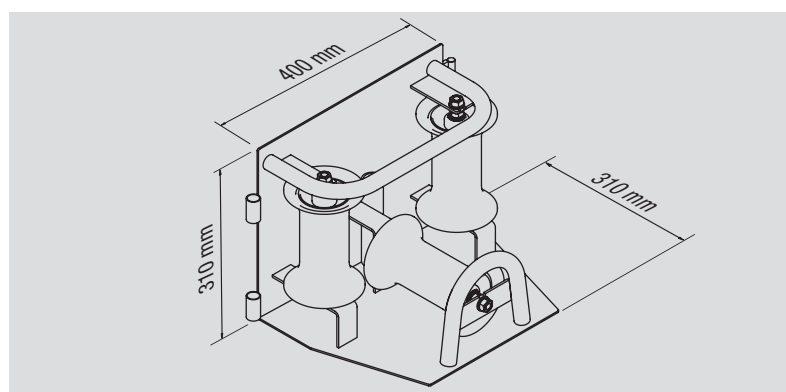

<p>EN</p> <p>Cable laying ground roller fit for corner installations of cables with ø 135 mm max. Composed by:</p> <ul style="list-style-type: none"> galvanized steel frame with flat ground base and back side n. 3 running rollers made of galvanized steel mounted on shielded ball bearings 	<p>D</p> <p>Kabelverlege-Eckrolle, geeignet zum Verlegen in Kurven von Kabeln bis max. ø 135 mm. Bestehend aus:</p> <ul style="list-style-type: none"> verzinktem Stahlgestell, mit flacher Rücken- und Bodenplatte drei Rollen aus verzinktem Stahl, gelagert mittels doppelt geschützter Kugellager 	<p>E</p> <p>Rodillo de tendido de cables para el tendido en curva de cables con ø 135 mm máx. Compuesto por:</p> <ul style="list-style-type: none"> bastidor de acero galvanizado con placa de fondo/lateral plana 3 rodillos de deslizamiento en acero cincado montado sobre cojinetes de esferas apantallados 	<p>F</p> <p>Rouleaux câblé adapté pour la pose incurvée de câbles mesurant jusqu'à ø 135 mm max. Composé de :</p> <ul style="list-style-type: none"> châssis en acier zingué avec plaque de base/latérale plate 3 galets en acier galvanisé montés sur roulements à billes blindés 	<p>I</p> <p>Rullo posacavi adatto per la posa in curva di cavi fino al ø 135 mm max. Composto da :</p> <ul style="list-style-type: none"> telaio in acciaio zincato con base e schienale piatti n. 3 rulli di scorrimento in acciaio zincato montati su cuscinetti a sfere schermati
--	---	---	--	--

Accessories • Zubehör • Accesorios • Accessoires • Accessori

<p>[1] Spare roller comes complete of screwed shaft M16, ball-bearings, nuts and bolts.</p>	<p>[1] Ersatzrolle aus verzinktem Stahl, mit Gewindestift M16, Kugellager, Beilagscheiben und Mutter.</p>	<p>[1] Rodillo de repuesto con perno roscado M16, cojinetes, arandelas y bulones.</p>	<p>[1] Galet de rechange muni d'axe fileté M16, roulements, rondelles et boulons.</p>	<p>[1] Rullo di ricambio, completo di perno filettato M16 cuscinetti, rondelle e bulloni.</p>
--	--	--	--	--



400 x 310 x 310 mm	14,5 kg	600 daN	300 daN	ø 135 mm	ø 80 - 109 x 180 mm

Subject to technical changes without prior notice. Technische Änderungen vorbehalten. Soggetto a variazioni tecniche senza preavviso.