

- | | | | | |
|---|---|---|---|---|
| <p>EN
 Folding cable run-off frame from the drum, fit for installations cables/pipes with ø 180 mm max. Composed by:</p> <ul style="list-style-type: none"> galvanized steel frame two running rollers made of galvanized steel mounted on shielded ball bearings | <p>D
 Kabelleit- und Ablaufbock zur Verlegung von Kabeln/Leerrohren bis zu einem ø von 180 mm, zusammenklappbar. Bestehend aus:</p> <ul style="list-style-type: none"> verzinkten Stahlrahmen zwei Rollen aus verzinktem Stahl, gelagert mittels doppelt geschützter Kugellager | <p>E
 Rodillo centrador guiacables en la salida de la bobina para cables/tubos con un ø máx. de 180 mm, versión plegable. Compuesto de:</p> <ul style="list-style-type: none"> bastidor en acero cincado dos rodillos de deslizamiento en acero cincado montados sobre cojinetes de esferas apantallados. | <p>F
 Galet en V de déroulage de câbles de la bobine pour câbles/tubes du ø de 180 mm max., version pliante. Comprenant:</p> <ul style="list-style-type: none"> un châssis en acier galvanisé deux galets en acier galvanisé montés sur roulements à billes blindés | <p>I
 Cavalletto guidacavo in uscita dalla bobina, per cavi/tubi fino al ø 180 mm max., versione ripiegabile. Composto da:</p> <ul style="list-style-type: none"> telaio in acciaio zincato due rulli di scorrimento in acciaio zincato montati su cuscinetti a sfere schermati |
|---|---|---|---|---|

Accessories • Zubehör • Accesorios • Accessoires • Accessori

- | | | | | |
|--|--|--|--|---|
| <p>[1] Spare roller comes complete of screwed shaft M12, ball-bearings, nuts and bolts.</p> | <p>[1] Ersatzrolle aus verzinktem Stahl, mit Gewindestift M12, Kugellager, Beilagscheiben und Mutter.</p> | <p>[1] Rodillo de repuesto con perno roscado M12, cojinetes, arandelas y bulones.</p> | <p>[1] Galet de rechange muni d'axe fileté M12, roulements, rondelles et boulons.</p> | <p>[1] Rullo di ricambio, completo di perno filettato M12, cuscinetti, rondelle e bulloni.</p> |
|--|--|--|--|---|

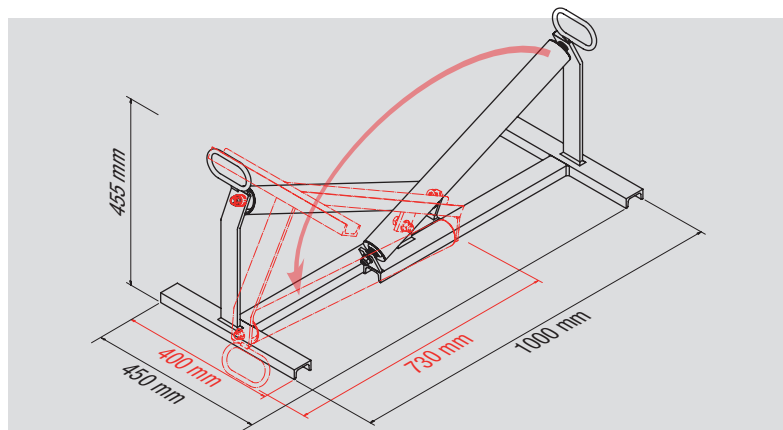

1000/730 x 450/400 x 455 mm	16,5 kg	100 daN	ø 180 mm	ø 60 x 605 mm	3,5 mm

Subject to technical changes without prior notice. Technische Änderungen vorbehalten. Sujeto a variaciones técnicas sin previo aviso. Sujet à des modifications techniques sans préavis. Soggetto a variazioni tecniche senza preavviso